



EZ2729sc Total Nitrogen Analyser

Applications

- Wastewater
- Drinking Water
- Power Generation
- Surface Water



Reliable, Scalable Systems Designed for Peak Performance

The EZ sc Series of online analysers delivers robust, efficient, and future-ready solutions for facilities striving to maximise operational uptime and meet evolving demands. Engineered with precision and backed by expert support, EZ sc systems integrate flexibility, providing durable performance, intuitive tools, and the ability to scale, all while minimising downtime and maintenance requirements.

Trusted Equipment for Critical Operations

The EZ sc Series combines robust engineering with high-quality materials to ensure reliability 24/7. Designed for long-term performance, EZ sc Series minimises breakdowns and supports sustained operational success.

Scalable Solutions for Growing Needs

Built to evolve alongside your needs, online analysers from the EZ sc Series offer adaptable parameters and easier integration. They ensure your facility remains future proof without requiring expensive upgrades. Easily adjust parameter testing ranges and expand sample streams to accommodate innovation and growth.

Real-Time Data for Faster Decisions

The EZ sc Series offers advanced connectivity and real-time monitoring, delivering immediate access to actionable insights. Facilities utilising this technology benefit from improved reaction times, empowering more informed decision-making and quicker responses during critical situations.

Simplified Troubleshooting with Expert Support

Built-in diagnostics combined with secure remote data access make the EZ sc Series simplify issue resolution. Supported by a highly responsive team of experts, it ensures uninterrupted functionality and minimises operational downtime. By addressing and identifying issues early, EZ sc Series of online analysers helps prevent costly disruptions and repairs while maintaining system efficiency.

Clear Workflows for Predictable Outcomes

Standardised tools and guided workflows ensure consistent implementation and operation. The EZ sc Series minimises miscommunication, sets clear expectations, and reduces process inconsistencies, driving greater efficiency.

Technical Data*

Model	EZ2729sc
Parameter	Nitrogen-Total
Measurement method	NEDD colorimetric method after reduction with hydrazine
Measuring range	Internal Dilution 0.25 - 10 mg/L TN 0.5 - 20 mg/L TN 1.25 - 50 mg/L TN 2.5 - 100 mg/L TN
Detection limit	0.25 - 10 mg/L TN: 0.25 mg/L 0.5 - 20 mg/L TN: 0.5 mg/L 1.25 - 50 mg/L TN: 1.25 mg/L 2.5 - 100 mg/L TN: 2.5 mg/L
Precision	Better than 4% full scale range for standard test solutions
Cycle time	Default: 45 min. Continuous: 36 min.
Sample temperature	10 - 30 °C
Reagent requirements	Keep reducing and colour solution refrigerated: 10 - 15 °C. All other reagents between 10 - 30 °C
Sample quality	Maximum particle size 100 µm, < 0.1 g/L; Turbidity < 50 NTU
Interferences	Ions, e.g., antimony (III) (Sb ³⁺), bismuth (III) (Bi ³⁺), chloroplatinate (PtCl ₆ ²⁻), gold (III) (Au ³⁺), iron (III) (Fe ³⁺), lead (II) (Pb ²⁺), mercury (II) (Hg ²⁺), metavanadate (VO ₃ ⁻) and silver (I) (Ag ⁺) can cause precipitation with nitrate. Copper (Cu ²⁺) ions can decompose the diazonium salt and cause a low result. NCl ₃ can cause a red color. Strong oxidizing agents interfere. Large quantities of color and turbidity interfere. Fats, oil, proteins, surfactants and tar interfere.
Demineralised water	Internal dilution option: Rinse water & Dilution water
Power	120 VAC, 50/60 Hz Max. power consumption: 240 VA
Automatic cleaning	Yes; Frequency freely programmable: 6 hours, 12 hours, daily, weekly
Calibration	Automatic; 2-point; offset or slope; Frequency freely programmable: 6 hours, 12 hours, daily, weekly. Note: manufacturer recommends that a calibration is done when the reagents are replaced
Validation	Automatic; Frequency freely programmable: 6 hours, 12 hours, daily, weekly
Ambient temperature	10 - 30 °C ± 4 °C deviation at 5 - 95% relative humidity (non-condensing)
Sample pressure	By external overflow vessel (open to atmospheric pressure)
Flow rate	100 - 300 mL/min
Instrument air	Dry and oil free according to ISA-S7.0.01-1996 quality standard for instrument air. Used to flush the instrument in corrosive environment. Min. 0.2 bar - Max. 0.5 bar
Drain	Atmospheric pressure, vented, min. Ø 32 mm
Earth connection	Dry and clean earth pole with low impedance (< 1 Ohm) using an earth cable of > 2.5 mm ²
Analogue outputs	Active 0 - 20 mA (or 4 - 20 mA) max. 500 Ohm load, standard: 4, optional: 8
Outputs	Optional: Claros Ethernet connection and Modbus TCP/IP Ethernet connector; LAN version; 10/100 Mbps or Profinet or Ethernet IP
Digital outputs	Profibus DP or Modbus RTU
Relays	5 contacts, not user configurable: Malfunction, maintenance, analysis ready, sample ready, sample ready (EZ9150)
Protection class	IP44
Material	Hinged part: Thermoform ABS, door: PMMA Wall section: Galvanised steel, powder coated
Dimensions (H x W x D)	688 mm x 460 mm x 340 mm
Weight	Max. 35 kg
Certifications	CE, ETL certified to UL and CSA safety standards, UKCA

*Subject to change without notice.

Dimensions

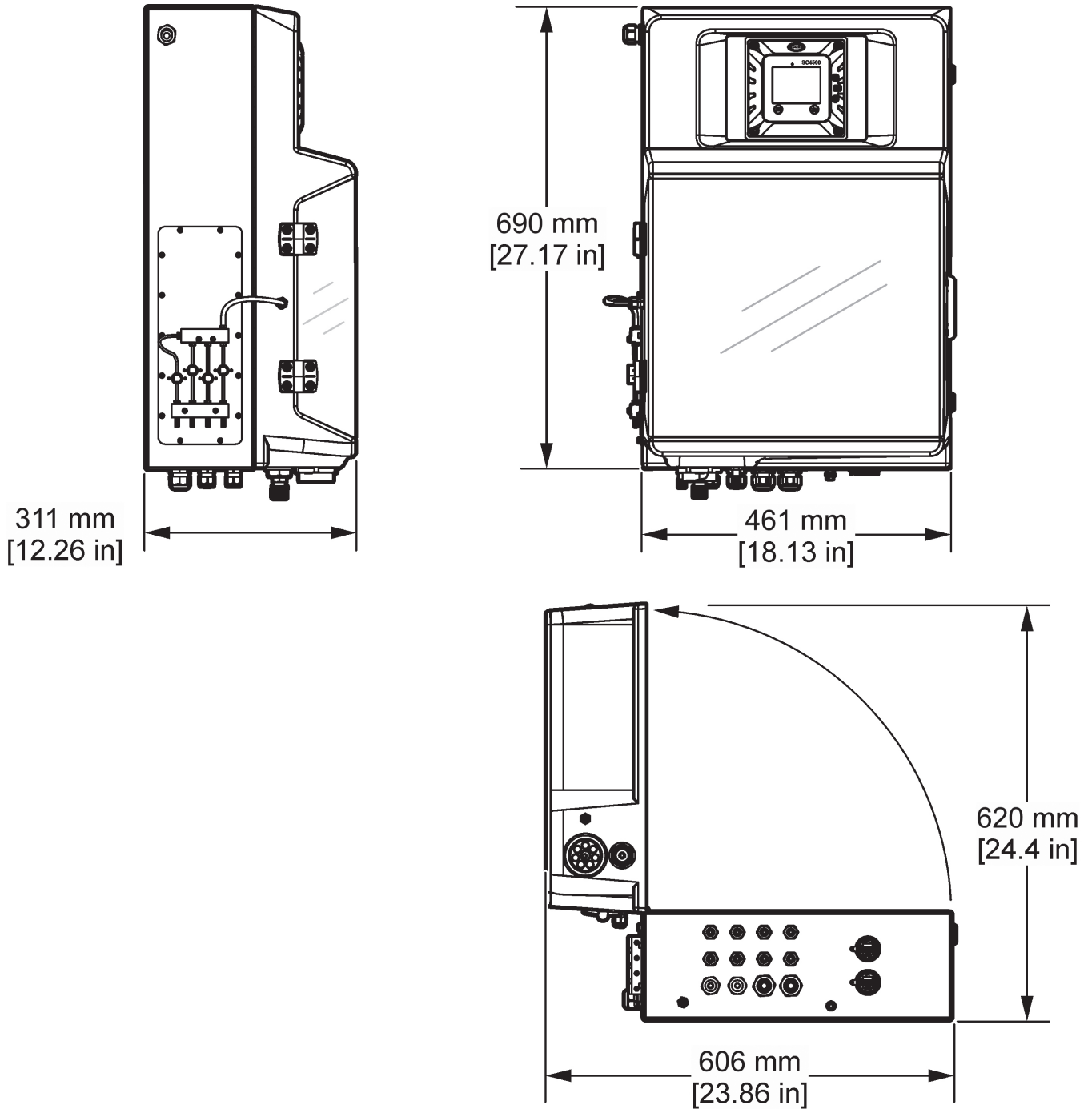

Enable the Benefits of Smart Monitoring

This instrument connects to Claros, Hach's innovative Water Intelligence System. Claros allows you to seamlessly connect and manage instruments, data, and process – anywhere, anytime. The result is greater confidence in your data and improved efficiencies in your operations. To unlock the full potential of Claros, insist on Claros Enabled instruments.

Hach Service Protects Your Investment

With Hach Service, you have a global partner who understands your needs and cares about delivering timely, high-quality service you can trust. Our Service Team brings unique expertise to help you maximise instrument uptime, ensure data integrity, maintain operational stability, and reduce compliance risk.

Order Information

EZ2729.98	X	X	X	X	X
Measurement range					
Internal Dilution	V				
0.25 - 10 mg/L TN					
0.5 - 20 mg/L TN					
1.25 - 50 mg/L TN					
2.5 - 100 mg/L TN					
Power supply					
230 VAC, 50/60 Hz		A			
120 VAC, 50/60 Hz		B			
Max. power consumption: 240 VA					
Number of sample streams					
1 stream			1		
Outputs					
4x mA				4	
8x mA				8	
4x mA + Modbus RTU				D	
8x mA + Modbus RTU				E	
4x mA + Modbus TCP/IP				I	
8x mA + Modbus TCP/IP				J	
4x mA + Profinet				N	
8x mA + Profinet				O	
4x mA + Profinet DP				S	
8x mA + Profinet DP				T	
4x mA + Ethernet/IP				X	
8x mA + Ethernet/IP				Y	
No adaption, "SC4500" version					OT

Accessories

APPAZ0080002 - Moduplex, 2 streams, Pinch Valve, 1/8" OD

APPAZ0080004 - Moduplex, 4 streams, Pinch Valve, 1/8" OD

APPAZ0080008 - Moduplex, 8 streams, Pinch Valve, 1/8" OD

